

20/21  
PRODUCTS

Product Catalogue  
**Fire Damper**  
Type ( FDM )



**Khedr Trust**  
ALL AIR PRODUCTS

Fire Damper products are manufactured by



“Your comfort is  
our priority”

[www.khedr-eg.com](http://www.khedr-eg.com)

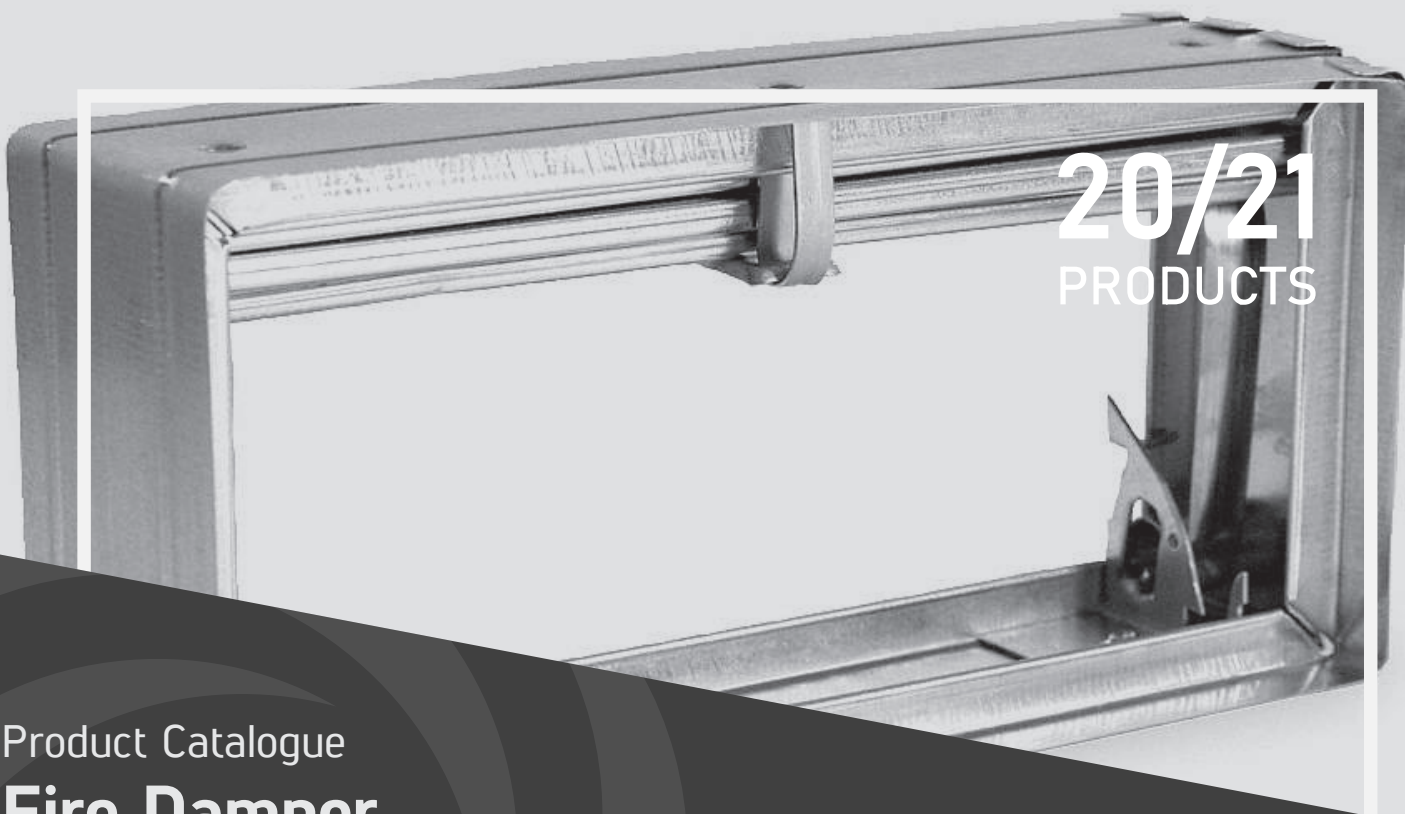



### Models

- FDM-A
- FDM-B
- FDM-C
- FDM-CR
- FDM-OV



### Features

- Damper Blades are precision roll formed and then interlocked to provide an angular, Heat deflecting construction.
- Dampers are supplied with two constant force St. Steel closure spring and locking ramp to ensure positive closure.
- UL Listed Fusible Link " 165 F Fusing Temperature " .
- All Dampers are Fire rated for 1 1/2 hour.
- Springs and Sealing are Stainless Steel.



# Fire Damper

## Model Design

Khedr Model FDM Curtain Bladed Fire Damper are designed to stop Through duct wall penetration.

## NFPA 90

Khedr Model FDM meets the latest requirements of NFPA 90.

## Model Types

Khedr Models FDM are suitable to use in vertical or Horizontal installation.

**- Construction & Specs.**

**- Type (FDM-A)**

(1.5mm) Galvanized Steel Frame.  
 (0.8mm) Interlocking Type Galvanized Steel.  
 55 to 78 % Free Area of nominal Size

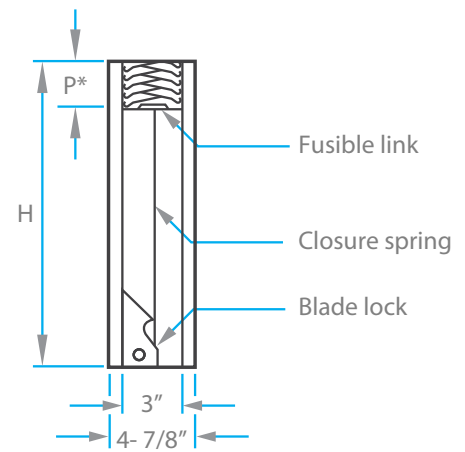
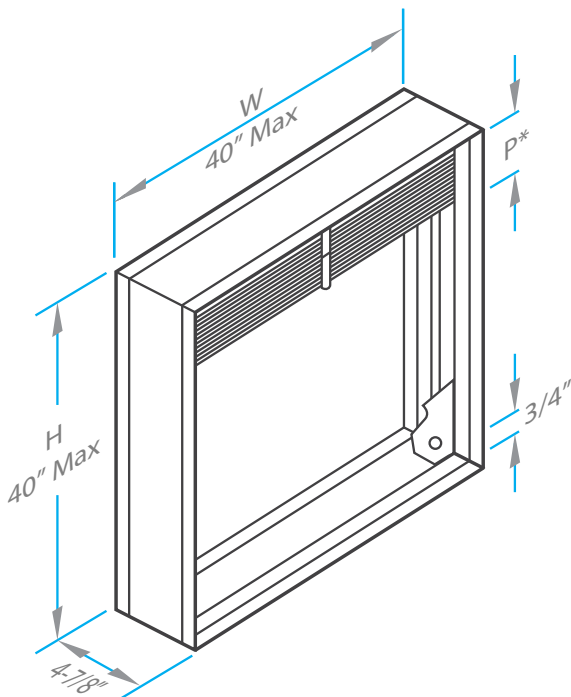

H/W "In"	P "In"	H/W "In"	P "In"	H/W "In"	P "In"
6	1	18	2 1/4	30	3 1/2
8	1 1/4	20	2 1/2	32	3 3/4
10	1 1/2	22	2 3/4	34	4
12	1 3/4	24	3	36	4
14	2	26	3	38	4 1/4
16	2	28	3 1/4	40	4 1/2

Fire Damper products are manufactured by Khedr Trust Co.

**- Type (FDM-B)**

(1.5mm) Galvanized Steel Frame.  
 (0.8mm) Interlocking Type Galvanized Steel.  
 91 to 95 % Free Area of nominal Size

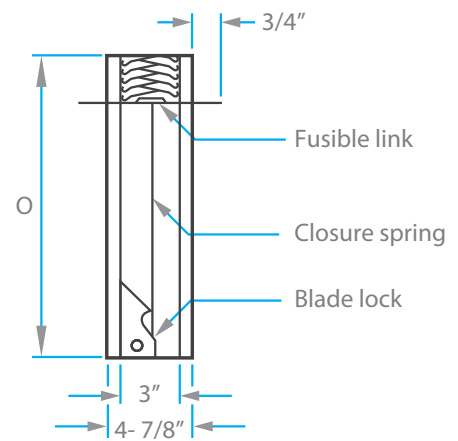
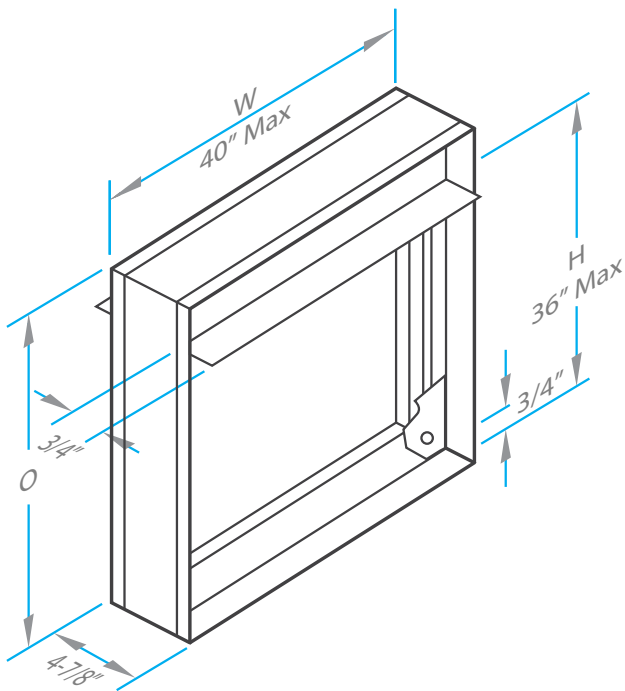

H/W "In"	O "In"	H/W "In"	O "In"	H/W "In"	O "In"
6	7 7/16	18	20 5/8	30	33 7/8
8	9 5/8	20	22 7/8	32	36 1/16
10	11 7/8	22	25 3/32	34	38 3/8
12	14 1/8	24	27 3/8	36	40 5/16
14	16 3/8	26	29 3/8		
16	18 3/8	28	31 5/8		

Fire Damper products are manufactured by Khedr Trust Co.

**- Type (FDM-C)**

(1.5mm) Galvanized Steel Frame.  
 (0.8mm) Interlocking Type Galvanized Steel.  
 100 % Free Area of nominal Size

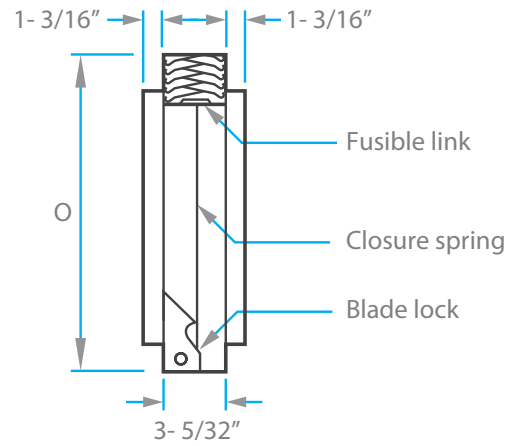
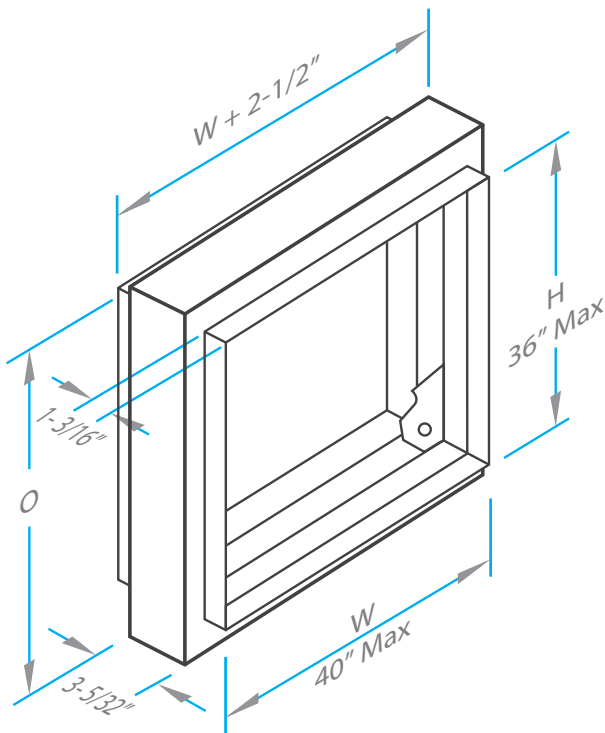

H/W "In"	O "In"	H/W "In"	O "In"	H/W "In"	O "In"
6	8 5/8	18	21 3/4	30	35
8	10 3/4	20	24 1/64	32	37 1/4
10	13 1/32	22	26 1/4	34	39 1/2
12	15 5/16	24	28 9/16	36	41 1/2
14	17 9/16	26	30 1/2		
16	19 9/16	28	32 3/4		

Fire Damper products are manufactured by Khedr Trust Co.

**- Type (FDM-CR)**

(1.5mm) Galvanized Steel Frame.  
 (0.8mm) Interlocking Type Galvanized Steel.  
 100 % Free Area of nominal Size

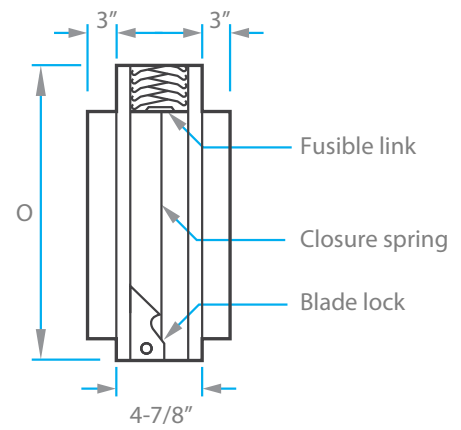
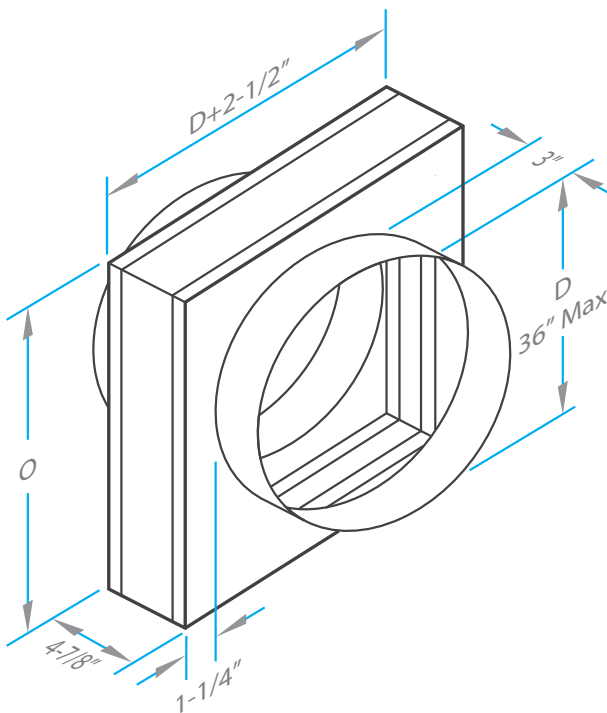

H/W "In"	O "In"	H/W "In"	O "In"	H/W "In"	O "In"
6	8 5/8	18	21 3/4	30	35
8	10 3/4	20	24 1/64	32	37 1/4
10	13 1/32	22	26 1/4	34	39 1/2
12	15 5/16	24	28 9/16	36	41 1/2
14	17 9/16	26	30 1/2		
16	19 9/16	28	32 3/4		

Fire Damper products are manufactured by Khedr Trust Co.

**- Type (FDM-OV)**

(1.5mm) Galvanized Steel Frame.  
 (0.8mm) Interlocking Type Galvanized Steel.  
 100 % Free Area of nominal Size

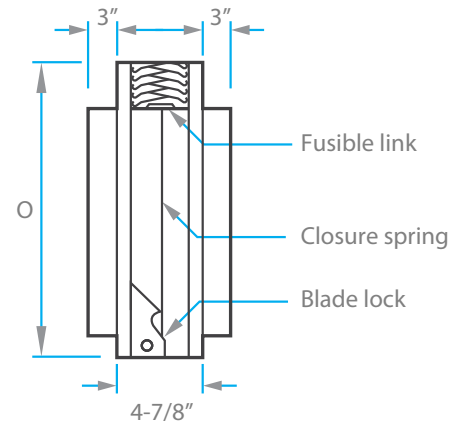
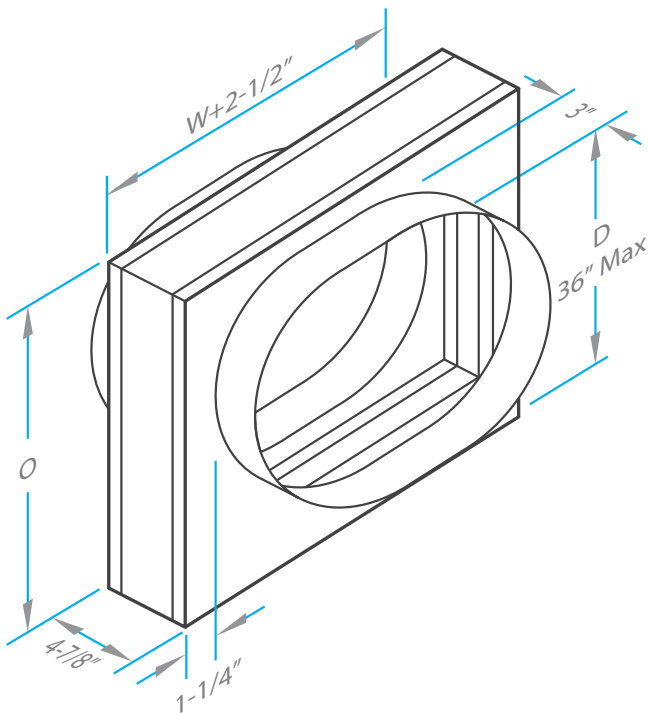

H/W "In"	O "In"	H/W "In"	O "In"	H/W "In"	O "In"
6	8 5/8	18	21 3/4	30	35
8	10 3/4	20	24 1/64	32	37 1/4
10	13 1/32	22	26 1/4	34	39 1/2
12	15 5/16	24	28 9/16	36	41 1/2
14	17 9/16	26	30 1/2		
16	19 9/16	28	32 3/4		

Fire Damper products are manufactured by Khedr Trust Co.



**- Aerodynamic Data**

**- Type (FDM-A)**

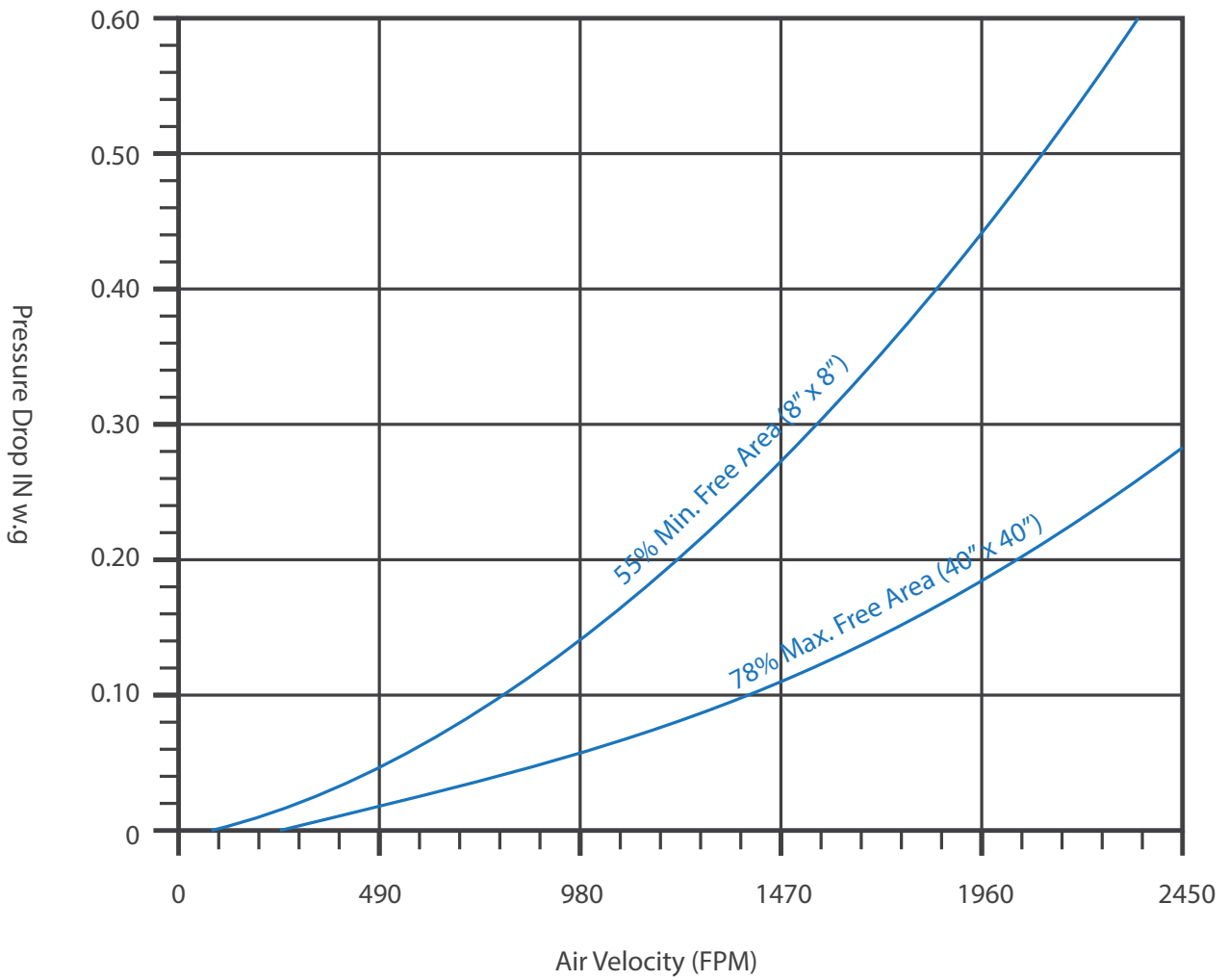

- Type (FDM-B)

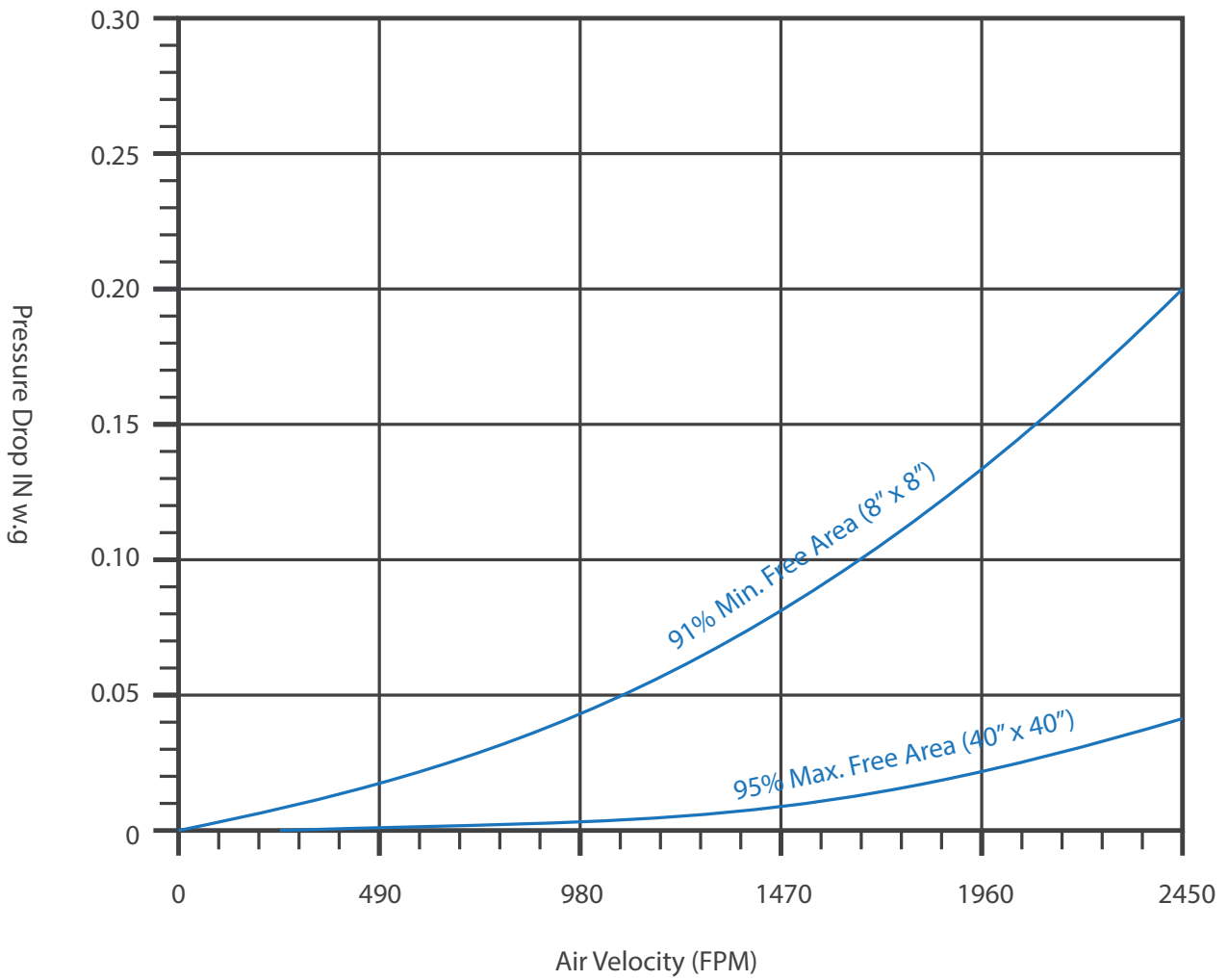

- Type (FDM-C, C(CR & OV))

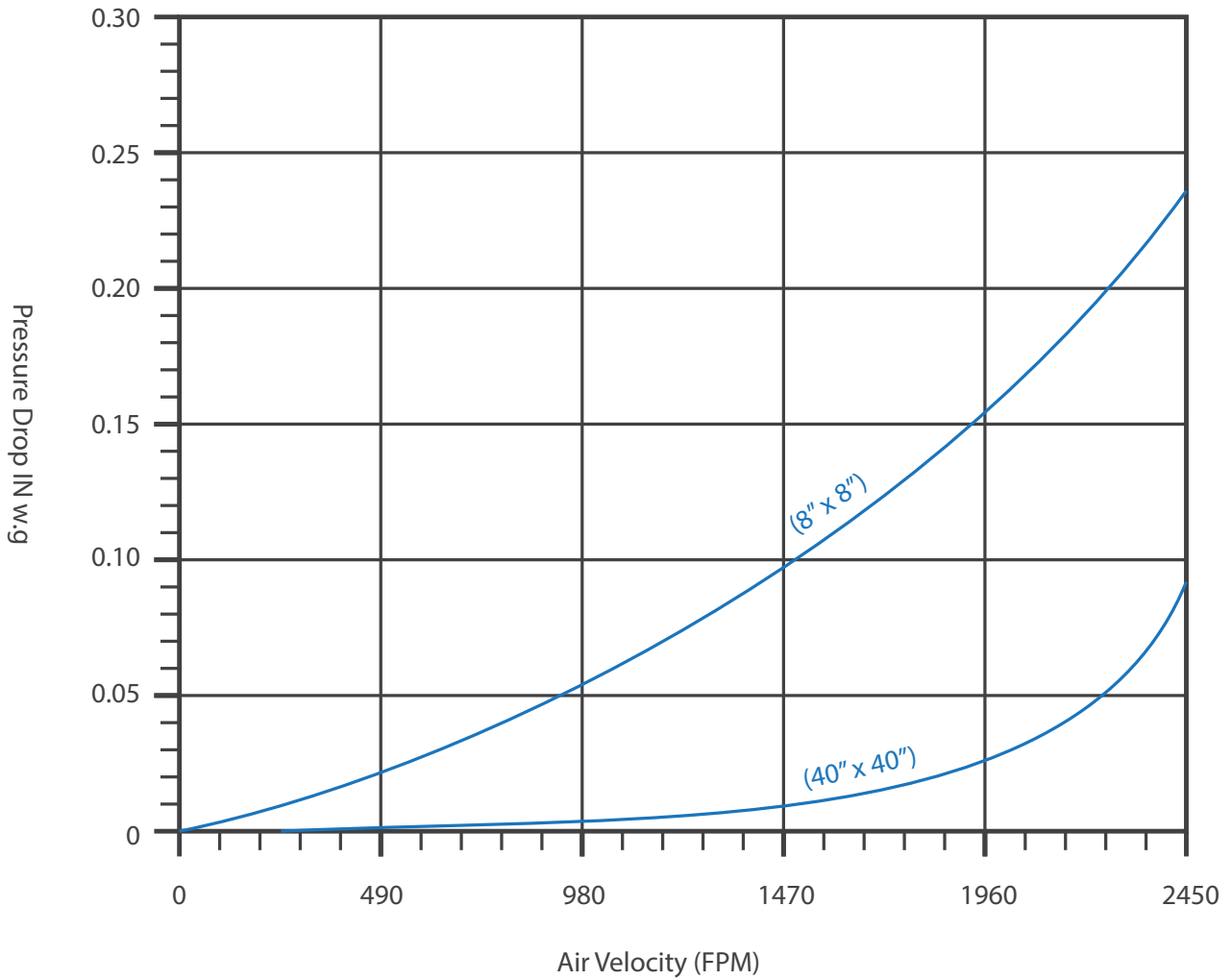

- How to order

Type	FDM-A	FDM-A FDM-B FDM-C FDM-CR FDM-OV	Fire Damper products are manufactured by Khedr Trust Co.
Size	24 x 24	Size "Inch"	
Frame	0	O Standard S Sleeve F Frame	

Other Products are provided by Khedr Trust Co.

#### Diffusers & Grills

Slot Linear Diffuser  
Eye Ball Diffuser  
Circular Ceiling Diffuser  
Swirl Diffuser  
Perforated Ceiling Diffuser  
Jet Diffuser  
Square Ceiling Diffuser  
Disc Valve Diffuser  
Linear Bar Grill  
Supply / Return Grill  
Door Grill

#### Louvers

Aluminum Louver  
Sand Trap Louver

#### Dampers

Volume Damper  
Fire Damper  
Smoke Motorized Damper  
Shutter Damper  
Pressure Relief Damper

#### Special Parts

Sound Attenuator  
Plenum Box

#### Duct Works

Galvanized Steel Duct  
Black Steel Duct  
Stainless Steel Duct  
Spiral Duct  
Flexible Duct  
Canvas  
Flanges  
Flexible Duct Connector



# Khedr Trust

ALL AIR PRODUCTS



Alqanater Alkhairia roads.Industrial Area. Behind Cocacola Co.. Cairo, Egypt

Mailing Address : P.O.Box 13621. Cairo 11511 - Egypt

Tel : +202 42452022

Mob : +2010 29999054 / +2010 29999056

+2010 29999057 / +2010 29999058

E-Mail : info@khedr-eg.com



www.khedr-eg.com

